

## Owner's manual

# AP05

## Personal Amplifier



Thank you very much for purchasing the AP05 personal amplifier. This manual provides the basics of the AP05. Read this before you use the unit for the first time.

## WARNINGS and PRECAUTIONS

- CAUTION: TO PREVENT ELECTRIC SHOCK, MATCH WIDE BLADE OF PLUG TO WIDE SLOT, FULLY INSERT.  
**ATTENTION: POUR PREVENIR LES CHOCS ELECTRIQUES, APAR DE LA FENTE LARGE, FOND.**

- WARNING: To reduce the risk of fire or electric shock, do not expose this apparatus to rain or moisture.  
**AVIS: Pour réduire le risque d'incendie ou de choc électrique, ne pas exposer cet appareil sous la pluie et l'humidité.**

- CAUTION: Use of any controls or adjustments or performance of procedures other than those herein specified may result in hazardous radiation exposure.

**ATTENTION: L'utilisation de tout contrôle ou de réglages ou de procédures autres que celles indiquées ci-après peut entraîner une exposition à des radiations dangereuses.**

- WARNING: Changes or modifications to this unit not expressly approved by the party responsible for compliance could void the user's authority to operate the equipment.

**AVIS: Les changements ou modifications à cette unité n'étant pas expressément approuvés par la partie responsable de la conformité pourraient annuler l'autorité de l'utilisateur de faire fonctionner l'équipement.**

- WARNING: Do not place the unit on top of any soft, porous, or sensitive surfaces to avoid damaging the surface. Use a protective barrier between the unit and surface to protect the surface.

**AVIS: Ne placez pas l'appareil au-dessus de toutes les surfaces souples, poreux, ou sensibles pour éviter d'endommager la surface. Utilisez une barrière de protection entre l'unité et la surface à protéger la surface.**

- WARNING: Use of this unit near fluorescent lighting may cause interference regarding use of the remote. If the unit is displaying erratic behavior move away from any fluorescent lighting, as it may be the cause.

**AVIS: L'utilisation de cet appareil à proximité d'éclairage fluorescent peut provoquer des interférences sur l'utilisation de la télécommande. Si l'appareil affiche un comportement erratique, s'éloigner de tout éclairage fluorescent, telle qu'elle peut être la cause.**

- WARNING: Do not install this equipment in a confined space such as a book case or similar unit.

**AVIS: Ne pas installer cet équipement dans un espace confiné comme une bibliothèque ou une unité similaire.**

### CAUTION

RISK OF ELECTRIC SHOCK  
DO NOT OPEN

WARNING: TO REDUCE THE RISK OF ELECTRIC SHOCK, DO NOT REMOVE COVER (OR BACK).

**AVERTISSEMENT: POUR RÉDUIRE LE RISQUE DE CHOC ÉLECTRIQUE, NE PAS ENLEVER LE COUVERCLE (NI LE DOS).**

### ATTENTION

RISQUE D'ÉLECTROCUTION  
NE PAS OUVRIR

NO USER-SERVICEABLE PARTS INSIDE. REFER SERVICING TO QUALIFIED SERVICE PERSONNEL.

**AUCUNE PIÈCE À L'INTÉRIEUR. ENTRETIEN DE PERSONNEL QUALIFIÉ.**



The lightning flash with arrowhead symbol, within an equilateral triangle, is intended to alert the user to the presence of uninsulated "dangerous voltage" within the product's enclosure that may be of sufficient magnitude to constitute a risk of electric shock to persons.

**Le symbole de l'éclair fêché dans un triangle équilatéral, est destiné à alerter l'utilisateur de la présence d'une "tension dangereuse" dans le boîtier du produit qui peuvent être des ampères suffisante pour constituer un risque d'électrocution aux personnes.**



The exclamation point within an equilateral triangle is intended to alert the user to the presence of important operating and maintenance (servicing) instructions in the literature accompanying the product.

**Le point d'exclamation dans un triangle attire l'attention de l'utilisateur sur la présence d'une importante littérature concernant le fonctionnement et l'entretien (les réparations) de l'appareil dans les manuels fournis.**

## SAFETY INSTRUCTIONS

- Read these instructions.  
**Lisez ces instructions.**
- Keep these instructions.  
**Conservez ces instructions.**
- Heed all warnings.  
**Respectez tous les avertissements.**
- Follow all instructions.  
**Suivez toutes les instructions.**
- Do not use this apparatus near water.  
**Ne pas utiliser cet appareil près de l'eau.**
- Clean only with dry cloth.  
**Nettoyer uniquement avec un chiffon sec.**
- Do not block any ventilation openings. Install in accordance with the manufacturer's instructions.  
**Ne pas bloquer les ouvertures de ventilation. Installer conformément aux instructions du fabricant.**
- Do not install near any heat sources such as radiators, heat registers, stoves, or other apparatus (including amplifiers) that produce heat.  
**Ne pas installer près de sources de chaleur telles que radiateurs, registres de chaleur, poêles ou autres appareils (y compris les amplificateurs) produisant de la chaleur.**
- Do not defeat the safety purpose of the polarized or grounding-type plug. A polarized plug has two blades with one wider than the other. A grounding type plug has two blades and a third grounding prong. The wide blade or the third prong are provided for your safety. If the provided plug does not fit into your outlet, consult an electrician for replacement of the obsolete outlet.  
**Ne détruisez pas la sécurité de la terre ou polarisées - fiche. Une fiche polarisée possède deux lames dont une est plus large que l'autre. Une prise de terre possède deux lames et une broche de terre. La lame large ou la troisième broche sont prévues pour votre sécurité. Si la fiche fournie ne rentre pas dans votre prise, consultez un électricien pour remplacer la prise obsolète.**
- Protect the power cord from being walked on or pinched particularly at plugs, convenience receptacles, and the point where they exit from the apparatus.  
**Protégez le cordon d'alimentation d'être piétiné ou pincé, particulièrement au niveau des fiches, des prises, et le point où ils sortent de l'appareil.**
- Only use attachments/accessories specified by the manufacturer.  
**N'utilisez que des accessoires spécifiés par le fabricant.**

- Use only with the cart, stand, tripod, bracket, or table specified by the manufacturer, or sold with the apparatus. When a cart is used, use caution when moving the cart/apparatus combination to avoid injury from tip-over.

**Utilisez seulement avec la charrette, position, trépied, support ou table spécifiée par le fabricant, ou a vendu avec l'appareil. Lorsqu'une charrette est utilisée, utilisez la prudence quand déplacer la combinaison de charrette / appareil pour éviter la blessure de pointe-sur.**



- Unplug this apparatus during lightning storms or when unused for long periods of time.  
**Débranchez cet appareil pendant les orages ou lorsqu'il n'est pas utilisé pendant de longues périodes de temps.**

- Refer all servicing to qualified service personnel. Servicing is required when the apparatus has been damaged in any way, such as power-supply cord or plug is damaged, liquid has been spilled or objects have fallen into the apparatus, the apparatus has been exposed to rain or moisture, does not operate normally, or has been dropped.

**Confiez toute réparation à un personnel qualifié. Une réparation est nécessaire lorsque l'appareil a été endommagé de quelque façon que ce cordon d'alimentation ou la fiche est endommagé, liquide a été renversé ou des objets sont tombés dans l'appareil, l'appareil a été exposé à la pluie ou à l'humidité, ne fonctionne pas normalement, ou s'il est tombé.**

- The apparatus shall be used in an open area.  
**Cet appareil doit être utilisé dans un endroit aère ouverte.**
- Apparatus shall not be exposed to dripping or splashing and that no objects filled with liquids, such as vases, shall be placed on apparatus.  
**L'appareil ne doit pas éclaboussures et aucun objet ne contenant de liquide, tel qu'un vase, ne doit être placé sur l'objet.**
- Mains plug is used as disconnect device. It shall remain readily operable and should not be obstructed during intended use. To completely disconnect the apparatus from supply mains, the main plug of the apparatus shall be disconnected from the mains socket outlet completely.  
**La prise du secteur et utilisé pour déconnecter le système. La prise du secteur ne doit pas être obstruée ou doit être facilement accessible pendant son utilisation. Pour être complètement déconnecté de l'alimentation d'entrée, la prise doit être débranchée du secteur.**

※ The type plate is located on the bottom of the apparatus.

## FCC (U.S.A.) & ICES-003 (Canada) INFORMATION

### 1. IMPORTANT NOTICE

This product, when installed as indicated in the instructions contained in this manual, meets FCC and ICES-003 requirements. Changes or modifications not expressly approved by Fostex Company for compliance could void the user's authority to operate the equipment. DO NOT MODIFY THIS PRODUCT.

### 2. IMPORTANT

In order to comply with FCC and ICES-003 requirements, use high quality shielded cables for connection to accessories and / or other products. If any cables are supplied with this product, they MUST be used. Follow all installation instructions. Failure to do so could void your FCC / ICES-003 authorization to use this product in the USA / Canada.

### 3. NOTE

This equipment has been tested and found to comply with the limits for a Class B digital device, pursuant to Part 15 of the FCC Rules. These limits are designed to provide reasonable protection against harmful interference in a residential installation. This equipment generates, uses and can radiate radio frequency energy and, if not installed and used in accordance with instructions, may cause harmful interference to radio communications. However, there is no guarantee that interference will not occur in a particular installation. If this equipment does cause harmful interference to radio or television reception, which can be determined by turning the equipment off and on, the user is encouraged to correct the interference by one or more of the following measures:

- Reorient or relocate the receiving antenna.
- Increase the separation between the equipment and receiver.
- Connect the equipment into an outlet on a circuit different from that to which the receiver is connected.
- Consult the dealer or an experienced radio/TV technician for help.

### 4. Compliance with Part 15 of FCC Rules and Canadian ICES-003.

This device complies with Part 15 of the FCC Rules. Operation is subject to the following two conditions: (1) This device may not cause harmful interference, and (2) this device must accept any interference received, including interference that may cause undesired operation.

This Class B digital apparatus complies with Canadian ICES-003.

Cet appareil numérique de la classe B est conforme à la norme NMB-003 du Canada.

## Functions and Connections

The AP05 is a personal stereo amplifier to drive a pair of passive loud speakers that amplifies audio signal from your PC or portable music player.

### <Note>

- 1) The power must be off when you make connections.
- 2) Do not short the speaker cable + and -.
- 3) The body may get hot during operation. Do not touch the bottom chassis with bare hands.
- 4) When the input signal level is too high, the output sound may get distorted. In such a case, lower the source side output level.

### 1. [INPUT] connector (stereo mini jack)

Connects to a stereo sound source, such as a personal computer and portable music player, using the supplied stereo mini plug cable.

### 2. [VOLUME] control

Controls the audio volume as well as turns on or off the power.

### 3. [SPEAKER] L channel terminal

Connects to a left channel passive loud speaker, using the supplied speaker cable.

### 4. [SPEAKER] R channel terminal

Connects to a right channel passive loud speaker, using the supplied speaker cable.

### 5. [DC IN] connector

Connects the supplied AC adaptor.

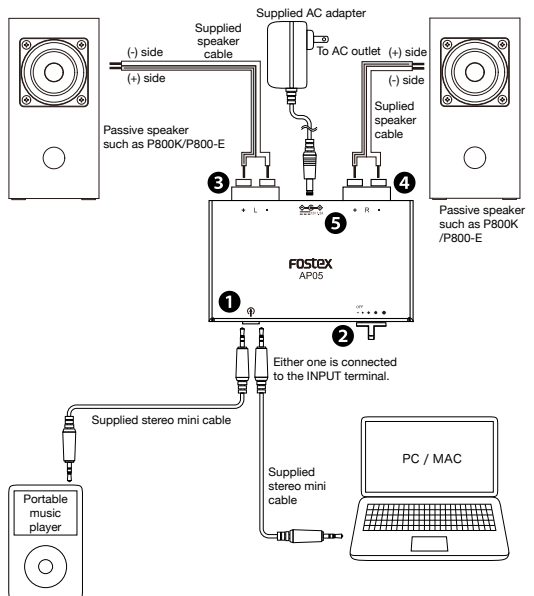

### <ErP Directive>

The AP05 conforms to ErP directive and pursues energy efficiency. Thus, when no-input signal continues for approx. 15 min, it will automatically go into the stand-by mode and its power withdrawal will become as low as 0.4W. At this moment, the power LED will change from Green lit to Red lit.

## Specifications

- Output power: 5W + 5W (RMS)
- Distortion (THD): less than 0.1% (1W output, 8Ω load, 1kHz)
- S/N ratio: 80dB or more (A-weighted)
- [INPUT] connector: Stereo mini jack, 630mV input sensitivity
- Power supply: DC 12V, 1.5A
- Power consumption: Approx. 22W (5W output), 0.4W (when in stand-by)
- External dimensions: 86mm(W) x 26mm(H) x 67mm(D) (including protrusions)
- Weight: 200g
- Supplied accessories: AC adapter x 1, speaker cable (1.5m) x 2, stereo mini cable (0.8m) x 1

### Declaration of EC Directive

This equipment is compatible with the EMC Directive (2004/108/EC) - Directive on approximation of member nation's ordinance concerning the electromagnetic compatibility and with the Low Voltage Directive (73/23/EEC) - Directive on approximation of member nation's ordinance concerning electric equipment designed to be used within the specified voltage range.

#### The Affect of Immunity on This Equipment

The affect of the European Specification EN61000-6-1 (coexistence of electromagnetic waves - common immunity specification) on this equipment are as shown below.

In the electrical fast transient/burst requirements, surge, conducted disturbances by radio-frequency fields, power frequency magnetic field, radiate electromagnetic field requirements and static electricity discharging environment, this could be affected by generation of noise in some cases.

### FOSTEX DISTRIBUTORS LIST IN EUROPE

\* Including non-EU countries (as of March 2012)

#### <AUSTRIA>

NAME: Mega Audio GmbH  
ADD: Stromberger Str. 32, D-55411 Bingen, Germany  
TEL: (+49) 6721-94330, FAX: (+49) 6721-32046

#### <BULGARIA>

NAME: Shark Art  
ADD: 15 Hristo Popovich Str., Varna 9000, Bulgaria  
TEL: (+359) 52-600172, FAX: (+359) 52-250578

#### <CZECHO>

NAME: Praha Music Center spol s.r.o.  
ADD: Ocelarska 937/39, Praha 9, 190 00, Czecho  
TEL: (+420) 226-011-111, FAX: (+420) 226-011-112

#### <DENMARK>

NAME: Benum Nordic A/S  
ADD: Meterbuen 18, Skovlunde, 2740 Denmark  
TEL: (+45) 4451-8900, FAX: (+45) 4451-8911

#### <FINLAND>

NAME: Noretron Oy Audio  
ADD: P. O. Box 22, FIN-02631 Espoo, Finland  
TEL: (+358) 9-5259330, FAX: (+358) 9-52593352

#### <FRANCE>

NAME: Sennheiser France  
ADD: 128 bis, avenue Jean-Jaures, 94851 Ivry-sur-Seine Cedex, France  
TEL: (+33) 1 4987 0300, FAX: (+33) 1 4987 0324

#### <GERMANY>

NAME: Mega Audio GmbH  
ADD: Stromberger Str. 32, D-55411 Bingen, Germany  
TEL: (+49) 6721-94330, FAX: (+49) 6721-32046

#### <GREECE>

NAME: Bon Studio S. A.  
ADD: 6 Zaimi Street, Exarchia, 106 83 Athens, Greece  
TEL: (+30) 210-3809-605, 606, 607, 608  
FAX: (+30) 210-3845-755, 210-3827-868

#### <HUNGARY>

NAME: ATEC Hungary Kft  
ADD: H-110/ Budapest, Fogado u. 3, Hungary  
TEL: (+36) 1-4319005, FAX: (+36) 1-4319006

#### <ITALY>

NAME: Prael S. p. A.  
ADD: Zona Via Alla Ruenna, 37/43 64027 - Sant'Omero (Teramo), Italy  
TEL: (+39) 0861-81241, FAX: (+39) 0861-887862

#### <THE NETHERLANDS>

NAME: IEMKE ROOS AUDIO B. V.  
ADD: Kuiperbergweg 20, 1101 AG Amsterdam, The Netherlands  
TEL: (+31) 20-697-2121, FAX: (+31) 20-697-4201

#### <NORWAY>

NAME: Siv. Ing. Benum AS  
ADD: P. O. Box 145, Vinderen, 0319 Oslo, Norway  
TEL: (+47) 2213 9900, FAX: (+47) 2214 8259

#### <POLAND>

NAME: Mega Music Spolka z o.o.  
ADD: Ul. Lesna 15, 81-876 Sopot, Poland  
TEL: (+48) 58-551-18-82, FAX: (+48) 58-551-18-72

#### <SPAIN>

NAME: Letusa S. A.  
ADD: C/Laguna 10, 28923 Alcorcon, Madrid, Spain  
TEL: (+34) 91-4862800, 91-4470898, FAX: (+34) 91-6414597

#### <SWEDEN>

NAME: Benum Nordic A/S  
ADD: Aldermansvagen 17, 171 48 Solna, Sweden  
TEL: (+46) 8 207710

#### <SWITZERLAND>

NAME: Audio Bauer Pro AG  
ADD: Bernerstrasse-Nord 182, CH-8064 Zurich, Switzerland  
TEL: (+41) 1-4323230, FAX: (+41) 1-4326558

#### <UK>

NAME: SCV London  
ADD: 40 Chigwell Lane, Oakwood Hill Industrial Estate, Loughton, Essex IG10 3NY U. K.  
TEL: (+44) 20-8418-0778, FAX: (+44) 20-8418-0624

**Fostex****FOSTEX CO.**

3-2-35, Musashino, Akishima-shi, Tokyo Japan, 196-0021